

# EDH SERIES ELECTRIC DUCT HEATERS

## DIAGRAMS

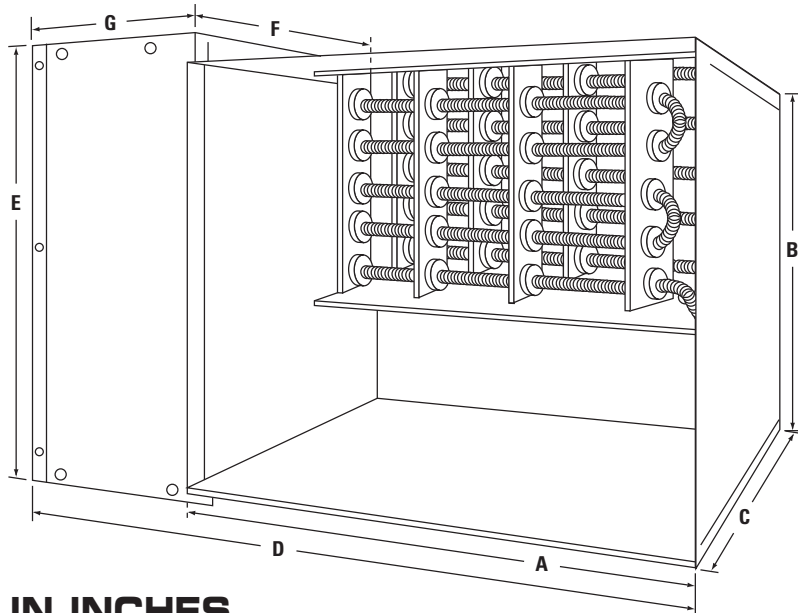

## DIMENSIONS IN INCHES

DEHUMIDIFIER MODEL #	DUCT HEATER MODEL#	KW	SUPPLY VOLTAGE	PHASE	DIMENSIONS IN INCHES						
					A	B	C	D	E	F	G
DCA 500/500WH	EDH500	4	220	1	9.25"	10.5"	16	21.25	12.5"	13	12
DCA 900/900WH	EDH900	7	220	1	13.375"	11.375"	16	25.375	13.375"	13	12
			208/230/460	3	13.375"	11.375"	16	25.375	13.375"	13	12
DCA 1400/1400WH	EDH1400	13	220	1	13.375"	11.375"	16	25.375	13.375"	13	14
			208/230	3	13.375"	11.375"	16	25.375	13.375"	13	12
			460/575	3	13.375"	11.375"	16	25.375	13.375"	13	12
DCA 2000/2000WH	EDH2000	15	220	1	15.75"	13.625"	16	27.75	15.625"	13	12
			208/230	3	15.75"	13.625"	16	27.75	15.625"	13	12
			460/575	3	15.75"	13.625"	16	27.75	15.625"	13	12
DCA 2500/2500WH	EDH2500	20	220	1	15.75"	13.625"	16	27.75	15.625"	13	12
			208/230	3	15.75"	13.625"	16	27.75	15.625"	13	12
			460/575	3	15.75"	13.625"	16	27.75	15.625"	13	12
DCA 3000/3000WH	EDH3000	30	220	1	18.75"	16.125"	16	30.75	18.125"	13	12
			208/230	3	18.75"	16.125"	16	30.75	18.125"	13	12
			460/575	3	18.75"	16.125"	16	30.75	18.125"	13	12
DCA 3300/3300WH	EDH3300	30	208/230	3	18.75"	16.125"	16	30.75	18.125"	13	12
			460/575	3	18.75"	16.125"	16	30.75	18.125"	13	12
DCA 3500	EDH3500	20	220	1	18.75"	16.125"	16	30.75	18.125"	13	12
DCA 3800/3800WH	EDH3800	40	208/230	3	18.75"	16.125"	16	30.75	18.125"	13	12
			460/575	3	18.75"	16.125"	16	30.75	18.125"	13	12
DCA 4000	EDH4000	20	220	1	18.75"	16.125"	16	30.75	18.125"	13	12
DCA 4200/4200WH	EDH4200	40	208/230	3	18.75"	16.125"	16	30.75	18.125"	13	12
			460/575	3	18.75"	16.125"	16	30.75	18.125"	13	12
DCA 5400/5400WH	EDH5400	50	208/230	3	18.75"	16.125"	16	30.75	18.125"	13	12
DCA 7000/7000WH	CONTACT FACTORY										
DCA 8000	CONTACT FACTORY										
DCA 9000	CONTACT FACTORY										
DCA 11000	CONTACT FACTORY										
DCA 14000	CONTACT FACTORY										

**NOTE:** Above duct heaters can be ordered with less KW than listed, for each model if needed.

## EDH SERIES ELECTRIC DUCT HEATERS



DCA (EDH series) electric duct heaters are engineered to provide additional room heating for all DCA dehumidification systems. These heaters provide an economical means to provide supplemental room heating.

The duct heater shown above is for direct mounting only and not downstream applications. Slip-in duct heater applications are available upon request. They are shipped unattached for on-site installation. A single high voltage power source, separate from the dehumidifier connection, and a low voltage connection are all that is required - allowing for an easy installation.

Every heater is shipped complete with air flow pressure switches, high limit controls and fuse blocks. The optional two-stage thermostat ties in with the 24-volt circuitry of any DCA dehumidifier. DCA also offers a complete line of gas fired in-line duct furnaces where these units may be desired.

All DCA electric duct heaters carry a one-year parts warranty.

## EDH SERIES ELECTRIC DUCT HEATERS

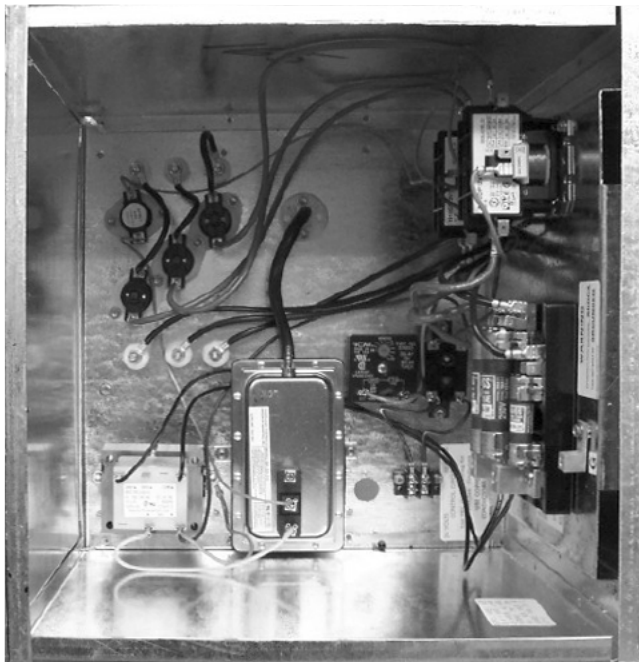

### STANDARD DCA FEATURES

- **MAGNETIC CONTACTORS**
- **AUTOMATIC HIGH LIMIT SWITCH**
- **AIRFLOW PRESSURE SWITCH**
- **24V TRANSFORMER**
- **PILOT RELAY**
- **STAGING AS REQUIRED FOR EACH 47 AMP CIRCUIT**
- **TIME DELAY BETWEEN STAGES**
- **SINGLE POINT POWER CONNECTION TO TERMINAL BLOCK**
- **LOW VOLTAGE TERMINAL STRIP**
- **GROUNDING LUG**
- **WELDED CONSTRUCTION USING 20 MSG GALVANIZED STEEL**
- **HINGED COVER**
- **WIRING DIAGRAM**
- **FUSED CIRCUITS PER N.E.C., UL, AND CSA**
- **UL AND CSA LISTED**
- **STRAIGHT FLANGE TO FIT UNIT DISCHARGE**
- **GRADE AA CHROMEL CORROSION-RESISTANT ELEMENT\***
- **SLIP IN DUCT HEATERS AVAILABLE**
- **DOWNFLOW DUCT HEATERS AVAILABLE**
- **SLIP IN DUCT, FINNED TUBULAR HEATERS, ALSO AVAILABLE - CONTACT FACTORY**

*\*For use within corrosive environments such as indoor swimming pool enclosures, chemical plants, water/wastewater treatment facilities, etc.*

## HORIZONTAL AND UPFLOW ONLY; (CONSULT FACTORY FOR DOWNFLOW APPLICATIONS)

DEHUMIDIFIER MODEL #	DEHUMIDIFIER HEATING CAPACITY AT 82° & 50% HR	ADD ON ELECTRIC		OUTLET CONNECTION WxH (inches)	TOTAL HEATING CAPACITY BTUH
		HEAT KW	CAPACITY BTUH		
DCA 500/500WH	10,500	4	13,656	8.375" x 10.5"	24,156
DCA 900/900WH	16,400	7	23,898	13.375" x 11.375"	40,298
DCA 1400/1400WH	25,250	13	44,382	13.375" x 11.375"	69,632
DCA 2000/2000WH	29,700	15	51,210	15.75" x 13.625"	80,910
DCA 2500/2500WH	41,250	20	68,280	15.75" x 13.625"	109,530
DCA 3000/3000WH	52,913	30	102,420	18.75" x 16.125"	155,333
DCA 3300/3300WH	61,177	30	102,420	18.75" x 16.125"	163,591
DCA 3500	61,177	20	68,280	18.75" x 16.125"	129,451
DCA 3800/3800WH	74,652	40	136,560	18.75" x 16.125"	211,185
DCA 4000	80,250	20	68,280	18.75" x 16.125"	148,530
DCA 4200/4200WH	80,250	40	136,560	18.75" x 16.125"	216,810
DCA 5400/5400WH	109,500	50	170,700	18.75" x 16.125"	280,200
DCA 7000/7000WH	CONTACT FACTORY				
DCA 8000	CONTACT FACTORY				
DCA 9000	CONTACT FACTORY				
DCA 11000	CONTACT FACTORY				
DCA 14000	CONTACT FACTORY				

NOTE: Above specifications for all DCA series Air-Cooled & Water-Cooled units.

### DUCT HEATER CURRENT DRAW (AMPS)

DEHUMIDIFIER MODEL#	KW	220/1	208/3	230/3	460/3	575/3
DCA 500/500WH	4	18.18	NA	NA	NA	NA
DCA 900/900WH	7	31.8	19.43	16.84	8.79	7.35
DCA 1400/1400WH	13	59.1	36.09	31.27	16.32	13.65
DCA 2000/2000WH	15	68.2	41.64	36.09	18.33	15.75
DCA 2500/2500WH	20	90.1	55.52	48.11	25.10	21.00
DCA 3000/3000WH	20/30	90.1	83.28	72.17	37.65	31.49
DCA 3300/3300WH	30	NA	83.28	72.17	37.65	31.49
DCA 3500	20	90.1	NA	NA	NA	NA
DCA 3800/3800WH	40	NA	111.03	96.23	50.21	40.16
DCA 4000	20	90.1	NA	NA	NA	NA
DCA 4200/4200WH	40	NA	111.03	96.23	50.21	40.16
DCA 5400/5400WH	50	NA	138.80	120.28	62.76	52.48
DCA 7000/7000WH	CONTACT FACTORY					
DCA 8000	CONTACT FACTORY					
DCA 9000	CONTACT FACTORY					
DCA 11000	CONTACT FACTORY					
DCA 14000	CONTACT FACTORY					

NOTE: (1) Control Voltage for above -24 volts

(2) Above specifications for all DCA series Air-Cooled & Water-Cooled units

(3) Above duct heaters can be ordered with less KW than listed, for each model if needed